



BEAVER COUNTY
BOX 140, RYLEY
Alberta, T0B 4A0

Ph: 780-663-3730 Fax: 780-663-3602

Application for
SUBDIVISION

For Office Use Only

File No.:	Roll No.:	Div.:	Receipt No.:
Date Received: MMM/DD/YY	Date Accepted as Complete:		MMM/DD/YY

This form is to be completed in full wherever applicable by the registered owner of the land or by an authorized person acting on behalf of the owner.

1. Name of registered owner(s) of land to be subdivided _____ Mailing address, postal code _____

 Email _____ Phone no. _____

Yes for Electronic Communication Authorization; In accordance with Section 608(1) of the Municipal Government Act, R.S.A. 2000, c. M-26, as amended, I/We grant consent to receive electronic communication by an authorized person of Beaver County relative to a subdivision application.

2. Authorized person acting on behalf of registered owner, if any _____ Mailing Address, postal code _____

 Email _____ Phone no. _____

Yes for Electronic Communication Authorization; In accordance with Section 608(1) of the Municipal Government Act, R.S.A. 2000, c. M-26, as amended, I/We grant consent to receive electronic communication by an authorized person of Beaver County relative to a subdivision application.

3. LEGAL DESCRIPTION AND AREA OF LAND TO BE SUBDIVIDED

All/part of the _____ ¼ section _____ township _____ range _____ west of the 4th meridian
Being all/parts of lot _____ block _____ plan _____ C.O.T. Number _____
Area of the above parcel to be subdivided _____ hectare _____ acres
Municipal Address (if applicable) _____

4. LOCATION OF LAND TO BE SUBDIVIDED

- a. The land is situated in the municipality of _____
- b. Is the land situated immediately adjacent to the municipal boundary? Yes _____ No _____
 If "yes" the adjoining municipality is _____
- c. Is the land situated within 1.6 km of the centre line of a highway right of way? Yes _____ No _____
 If "yes," the highway is number _____ the secondary road is number _____
- d. Does the proposed parcel contain or is it adjacent to a river, stream, lake or other body of water or by a drainage ditch or canal?
 If "yes" state its name _____
- e. Is the proposed parcel within 1.5 kilometers of a sour gas facility? Yes _____ No _____

5. EXISTING AND PROPOSED USE OF LAND TO BE SUBDIVIDED

- Describe
- a. Existing use of the land _____
- b. Proposed use of the land _____
- c. The designated use of the land as classified under the County's land use bylaw _____
- d. The proposed use designation _____

6. PHYSICAL CHARACTERISTICS OF LAND TO BE SUBDIVIDED (WHERE APPROPRIATE)

a. Describe the nature of the topography of the land (flat, rolling, steep, mixed)

b. Describe the nature of the vegetation and water on the land (brush, shrubs, tree stands, woodlots, sloughs, creeks, etc.)

c. Describe the kind of soil on the land (sandy, loam, clay, etc.)

7. EXISTING BUILDINGS ON THE LAND TO BE SUBDIVIDED

Describe any buildings and any structures on the land and whether they are to be demolished or moved

8. WATER AND SEWER SERVICES

If the proposed subdivision is to be served by other than a water distribution system and a wastewater collection system, describe the manner of providing water and sewage disposal

9. a. Total number of parcels being created (including remnant) _____

b. Size of parcel(s) being created (hectares and acres) _____

c. Proposed use of remainder of ¼ section or land presently in title _____

10. Please indicate if the land that is the subject of the subdivision application is situated within 1000 feet of land that is used or authorized for use as

a. a landfill for the disposal of garbage or refuse yes _____ no _____

b. a sewage treatment or sewage lagoon yes _____ no _____

c. a livestock feeding lot yes _____ no _____

11. What is the purpose/reason for the subdivision application? _____

(further information may be provided on a separate page)

12. REGISTERED OWNER OR PERSON ACTING ON THE REGISTERED OWNER'S BEHALF AND RIGHT OF ENTRY

I, _____ hereby certify that

I am the registered owner, or

I am the agent authorized to act on behalf of the registered owner(s),

and that the information given on the form is complete and is, to the best of my knowledge, a true statement of the facts relating to this application for subdivision approval. I/We hereby give my/our consent to allow Council or a person appointed by it the right to enter the above land with respect to this application only.

Signed _____

Home/Phone number _____ Dated _____ *MMM/DD/YY*

Signature of ALL Registered Owner(s) (if different from above) _____

Collection and use of personal information. This personal information is being collected in accordance with the Municipal Government Act (MGA) and the Land Use Bylaw (LUB) and is protected by the privacy provisions of the Freedom of Information and Protection of Privacy Act (FOIP), unless disclosures are authorized under the LUB. This information will be used to process and issue the decision.

Please send or email the completed form to Beaver County, Box 140, Ryley, AB, T0B 4A0
Phone: 780-663-3730 Fax: 780-663-3602 Email: administration@beaver.ab.ca

SUBDIVISION SKETCH EXAMPLE

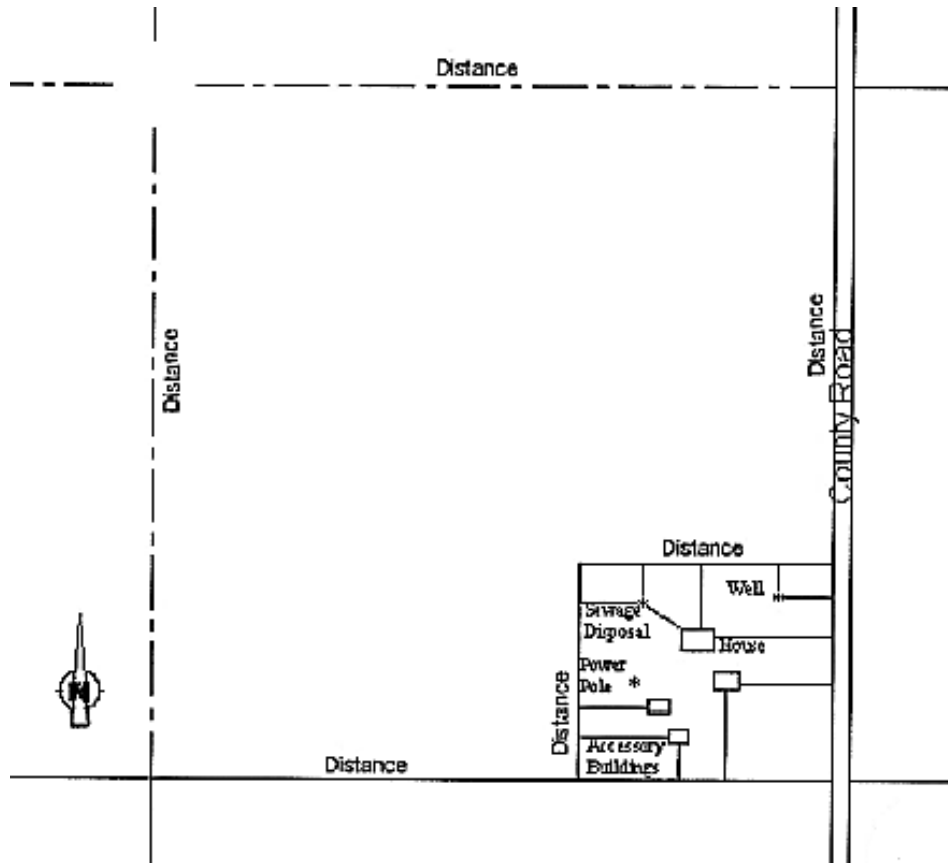

The Site Plan should include the following information in order for it to be considered complete:

- Approximate dimensions and boundaries of each lot to be subdivided;
- Location of all buildings on the land and approximate distance to all new property lines and indicate if any of the buildings will be removed or demolished;
- Label of all buildings with the use (i.e.: house, barn, fence);
- Distance of the sewage disposal system to the new property boundary(s) and the type of septic system;
- All approaches to the property and balance parcel;
- Approximate location of any waterbody including lakes, sloughs, creeks, drainage ditches, and dugouts;

NOTE: You can use an aerial photo from the County Office or Web Mapping Tool from the County website (<http://www.beaver.ab.ca/departments/planning-development/maps-webmapping>) as the base for your sketch, but you will need to ensure all the above information is included.

Your complete subdivision application must consist of the following:

- application fee (\$600 plus \$200 per new title)
- fully completed and signed application form
- current copy of certificate of title
- proposed subdivision plan showing buildings, approaches, septic system
- completed right-of-entry
- AER abandoned well information

Other information may be required.



SUBDIVISION APPLICATION

Note: these guidelines are intended to assist landowners in determining the requirements relating to subdividing lands. The process of subdividing lands follows all County policies and Provincial policies which may be difficult to interpret without having prior experience with subdividing. If you have questions pertaining to these policies, please contact Beaver County, a Professional Planner or Surveyor for clarification. If you have questions from the information provided, please contact the Beaver County Planning & Development Department.

INITIAL SUBDIVISION QUESTIONS

1. What is a subdivision?

Subdivision is the process of dividing a single parcel of land into two or more parcels as provided by Municipal and Provincial legislation. Subdivision can also be used for existing lot line adjustments between existing parcels of land. Each newly created parcel is issued its own registered title from an Alberta Land Titles Office.

2. Who makes the rules regarding subdivision of land?

In the Province of Alberta, the *Municipal Government Act* and the *Subdivision and Development Regulation* provide the legislative authority for Municipalities to regulate the subdivision of land within their municipal boundaries. Under the Provincial legislation, Beaver County is required to outline the subdivision rules and regulations in the County's Municipal Development Plan and Land Use Bylaw (e.g. maximum allowable lots and parcel sizes to be subdivided per quarter section).

3. Who can apply to subdivide land?

Land cannot be subdivided without the permission of the registered landowner(s). The registered landowner(s) may appoint an authorized agent to act on their behalf. The authorized agent may be someone familiar with the planning process such as a land use planning consultant or land surveyor.

4. Can my land be subdivided?

Prior to submitting a formal subdivision application and paying the necessary application fees, it is recommended that you set up a pre-subdivision meeting with the Planning & Development Department. This is important to understand the existing land use planning policies which may affect your subdivision application and determine the eligibility of your subdivision proposal. This will not however, be an answer as to whether or not your subdivision will be approved. In order to receive a decision or answer, you will be required to submit a formal subdivision application.

5. How much does it cost?

The cost of subdividing will vary depending on the complexity of the application. The initial subdivision application includes the application fee (\$600, plus \$200 for each new lot created including the balance parcel). Once the subdivision is conditionally approved, the following costs may be required prior to the endorsement of the subdivision:

- Endorsement fee (\$300 per lot including the balance parcel)
- Surveying costs
- Registering your parcel at the Land Titles Office
- Road/approach or other upgrade requirements
- Sewer system compliance letter and upgrades
- Consultation costs (e.g. planning consultant, geotechnical, traffic impact assessment, groundwater availability).
- Application for Plan and Zoning Amendments
- Cash-in-lieu of municipal reserves
- Any appeal fees required
- Other costs may be required

6. How long does it take?

The process of subdividing land can be a lengthy process and will depend on the complexity of your application. According to the *Subdivision and Development Regulations*, the Subdivision Authority is required to make a decision within 60 days of when the application is deemed to be complete. A complete application includes: fully completed and signed application form, application fee, current certificate of title, tentative subdivision plan, and other information as required by the Subdivision Authority.

A 30 day agency referral circulation period is included within the 60 day processing period. During this period, your completed application form and site plan is sent to local and provincial authorities for review and comments. Your application is required to be sent to adjacent landowners for any comments regarding the application. If the deadline to issue a decision cannot be met, the Subdivision Authority may request an extension beyond the 60 days.

THINGS TO CONSIDER IN YOUR SUBDIVISION PROPOSAL

7. Is the land suitable for the type of development I am proposing?

A suitable building site with a minimum of one (1) acre developable area must be available on the proposed parcel and on the remainder of the land.

8. How many parcels of land may I subdivide?

The number and size of parcels allowed is governed by Beaver County's Municipal Development Plan and Land Use Bylaw. These documents indicate the maximum number of parcels allowed under the land use designation and area of your land. For example, if your land is located in the Moraine Residential Area, a maximum of eight (8) parcels of land per quarter section may be subdivided. If it is located in the Agricultural Area, a maximum of three (3) parcels of land per quarter section may be subdivided.

Lots subdivided for a farmstead or country residential use shall be 1.2 – 4.0 hectares (3 – 10 acres) in size, but may be larger to include shelter belts, farm buildings, septic setback distance or natural features.

9. How will I access my proposed lot?

As a condition of subdivision approval, Beaver County requires the developer to provide a direct and legal physical access to each proposed lot of a subdivision. This access must be developed to the minimum required standards of Beaver County Public Works Department. Upgrades to the existing access may be required as determined by the Public Works Department.

10. How will sewage be disposed of?

The proposed parcel must have an adequate area that meets the minimum setback distances in which to dispose of sewage. The area required for sewage disposal will be dependent upon the type of system for the proposed development including the site and soil conditions of the parcel. For example, a new open discharge system requires a minimum setback distance of 91.1 m (300 ft.) setback from all property lines.

If you are unsure of the type of sewage disposal system suitable for your subdivision, or you are unsure whether your existing sewage disposal system will be compliant, please contact The Inspections Group at 1-866-554-5048 for more information.

SUBDIVISION PROCESS

11. How will my application be reviewed?

Your application will be reviewed and checked by the Planning staff to ensure that the proposal conforms to the Provincial and Municipal planning legislation. In addition, the land you are subdividing is evaluated according to:

- General terrain
- Soil characteristics
- Adequacy of the proposed building site
- The existence of direct physical and legal access
- The use of adjacent land
- Proximity to existing utilities
- Its relationship with or possible effect on future development of surrounding land
- A site inspection by County staff

12. What if a decision is not made within 60 days?

If the Subdivision Authority is not able to make a decision on your application within 60 days, we will ask you to give us additional time by sending you a time extension form. The time extension form may be completed and signed by you or your authorized agent. If an extension is not granted, the application is deemed to be refused and you may appeal this decision.

13. How does my subdivision get approved?

After reviewing the application, the Subdivision Authority will make a recommendation based on the information submitted with your application, the comments received from the referral agencies, Provincial and Municipal planning policies and regulations applying to the land. The Subdivision Authority may either approve with conditions or refuse your application. Written notice of the decision will be sent to you and the referral agencies. If your application is refused, reasons must be given.

14. What if my subdivision is refused?

A decision of conditional approval or refusal may be appealed to the Subdivision and Development Appeal Board or the Municipal Government Board where the appeal involves provincial interests. You or your authorized agent may appeal a decision of refusal or any condition attached to an approval. To appeal, you must send a written notice, stating reasons, and the \$200 appeal fee within 21 days of the date of decision to the Subdivision Authority. The Subdivision Authority's decision or conditions of approval may also be appealed by County Council, a provincial government department that has interest in the subdivision, or the local school authority. Adjacent landowners do not have the right to appeal.

Upon receipt of a notice of appeal, the Board will determine if there are valid grounds to hear the appeal. If an appeal is accepted, the Board will hear your arguments regarding the decision as well as any arguments put forward by the Subdivision Authority or referral agencies. The Board has the authority to uphold the Subdivision Authority's decision, reverse the decision or change any of the conditions attached to the decision.

15. What is a conditional approval?

A conditional approval is a decision in favour of your application subject to satisfactory completion of certain conditions. You will have one (1) year to meet all of the conditions of approval (see Subdivision Conditions Explained). During this period, you must arrange for an Alberta Land Survey to prepare and submit to the County, a final plan for endorsement. Once all the conditions have been met and the endorsement fees have been paid, the County will endorse the final plan.

You will have one (1) year from the date of endorsement in to have your final plan registered in the Alberta Land Titles Office. Upon registration of your final plan, new titles for the lots created will be issued by the Land Titles Office.

16. How do I request for an extension to my conditional approval?

Effective June 20, 2018, a fee will be charged to developers for requests for subdivision approval extensions. An extension may be necessary if additional time is needed to satisfy the conditions beyond the one (1) year time limit from the date of subdivision approval. The [Subdivision Approval Extension Request Form](#) must be completed in full and submitted to the County with the applicable fee for approval.

At the discretion of the Subdivision Authority, the application may be referred to affected agencies to ensure there is no new information that could affect the original subdivision approval.

If no referral is required, the extension fee is \$100 for the second and each subsequent extension request. If a referral is required, the extension fee is \$150 for each extension request.

SUBDIVISION CONDITIONS EXPLAINED

All subdivisions approved by Beaver County's Subdivision Authority include conditions that must be met before your plan of subdivision can be registered. The following are some common conditions that could be imposed on your subdivision approval. Note: In the case of differences in interpretation between the conditions approval letter and this document, the intent of the conditions approval letter shall apply.

- a) **Sample Condition 1:** Pursuant to Section 654(1)(d) of the Municipal Government Act, R.S.A. 2000, c. M-26, outstanding property taxes must be paid ...

This condition requires that the taxes for the current year must be paid in full. If enough time has elapsed between the time you apply for subdivision and the plan of survey is to be registered that a new tax year is in effect, and a tax notice has not yet been issued by Beaver County, contact the County Office for an estimate of taxes. ALL taxes must be paid before the County will notify the Subdivision Authority that this condition has been met.

- b) **Sample Condition 2:** That the owner pay the final endorsement fees to Beaver County ...

This condition requires the landowner/developer to pay the fee to have the subdivision plan endorsed by the Subdivision Authority. The cost is \$300 for each new lot created including the balance parcel.

- c) **Sample Condition 3:** The existing private sewage disposal system must comply with the Alberta Private Sewage Treatment and Disposal regulations ...

This condition requires that landowner/developer obtain a letter from the safety codes agency having jurisdiction in the County, indicating that the existing sewage system complies.

- d) **Sample Condition 4:** The applicant enter into a development agreement with Beaver County, with terms and conditions satisfactory to the County ...

This condition requires the landowner/developer to provide access to each parcel being created by subdivision. This usually involves the construction of a new approach and/or the upgrading of an existing approach. All new or existing approaches must meet the County's current specifications and minimum standards.

If, under extenuating circumstances, the subdivision must be registered before approaches have been constructed/upgraded, the County may permit the landowner/developer to enter into an agreement with the County for future construction/upgrading of the approach. In these cases, the landowner will be required to pay a deposit to the County equivalent to the estimated cost of construction.

In some cases, a development agreement may be required to address issues such as road improvements, provision of utility services, etc. The development agreement will be registered by caveat on the title of the parcels affected.

- e) **Sample Condition 5:** evidence prepared by an Alberta Lands Surveyor and submitted to Beaver County to confirm that the location of all improvements on the property conform to the County's Land Use Bylaw ...

This condition requires the landowner/developer to hire an Alberta Land Surveyor to prepare a sketch showing the dimensions of the proposed subdivision, dimensions of all improvements relative to the closest property lines (proposed or existing), and the location of the septic system (e.g. pump out, mound, etc.) to the proposed property lines.

f) **Sample Condition 6: Road Widening**

In some cases, the applicant will be required to dedicate some land adjacent to a County road throughout its entire length, by way of caveat or road acquisition agreement. The caveat or dedication allows the County to improve the road in the future without the need for road widening agreements.

g) **Sample Condition 7: Municipal Reserve Dedication**

In some cases, a municipal reserve dedication of land (e.g. for parks) may be required. If appropriate, the County's Subdivision Authority may elect to collect money-in-lieu of reserve land, or a combination of both. If land is to be dedicated, it must be shown on the plan of survey that will be endorsed by the Subdivision Authority.

In some cases where a municipal reserve dedication would normally be a condition of subdivision approval, the County's Subdivision Authority may choose to defer the dedication until sometime in the future. This condition is typically used if further subdivision is contemplated in the near future. The deferred reserve caveat will be registered by caveat against the titles of the parcels being created to inform future owners or other interested parties that municipal reserve may be taken in the future.

h) **Sample Condition 7: Environment or Conservation Reserve**

In some cases, an environment reserve dedication may be required if, in the opinion of the Subdivision Authority, the land is unsuitable for development or to preserve the natural features of the land. Examples include swamps, gullies, ravines, natural drainage courses, flood-prone areas or land immediately adjacent to a body of water.

A conservation reserve dedication of land may be required for the purpose of protecting and conserving the land with environmentally significant features or if the land cannot be taken for an environmental reserve; this must be consistent with the County's Municipal Development Plan. The County must compensate the landowner at market value for taking a conservation reserve.

For more information, please visit <http://www.beaver.ab.ca/departments/planning-development> or contact the Planning & Development Department at 780-663-3730 or email: administration@beaver.ab.ca.

INFORMATION REQUIRED FOR ANY SUBDIVISION APPLICATION
Pursuant to Part 1 of the *Subdivision and Development Regulations (AR 43/2002)*

Note: An application for subdivision approval can only be made by the registered owner of the land that is the subject of the application or a person authorized to apply on his behalf. (Part 1, Section 4(1) of *Subdivision and Development Regulations*)

The County will only accept an application for subdivision when **all** of the following information has been submitted.

1. Subdivision Application Fee

The application fee must be included in accordance with County Bylaws. The subdivision fees apply not only to the new lot(s) created under the subdivision plan, but also the lot which constitutes the remainder, excluding lots proposed as reserve or public utility lots.

- a. Fees are \$600.00 plus \$200.00 per lot created. The remaining parcel (remnant) is considered one lot for the purpose of subdivision. Example: First Parcel Out subdivision fee is \$600 + \$200 for new lot + \$200 for remnant lot = \$1,000. Thereafter, each new lot created is an additional \$200.
- b. Accepted forms of payment include debit, credit and cheque payable to Beaver County
- c. Application fee is non-refundable

2. Application Form

- a. Both sides of the Subdivision Application must be completed in its entirety and signed by all registered owners.
- b. Complete information for the names, address and telephone number(s) of the registered owner(s) and the authorized person(s) acting on behalf of the mentioned persons. If a person is acting on behalf of the registered owner(s), it is essential that all the registered owner(s) sign the authorization at the back of the application form. Please note that if a company or individual is the owner of the said land under an agreement for sale as indicated by caveat on the back on the Certificate of Title, please submit a copy of the signed agreement. The individual noted on the caveat must sign the application.

3. Sketch of the Proposed Subdivision, specifying the following:

- a. Approximate dimensions and boundaries of the land and each lot to be subdivided.
- b. Location of all buildings on the land and approximate distance to all new property lines and indicate if any of the buildings will be removed or demolished.
- c. Label all buildings with the use (e.g. house, barn, fence), shelterbelts, water well, power poles, gas lines, oil or gas well sites, underground storage tanks, approaches and private sewage system.
- d. Distance from the road to the closest permanent building.
- e. Distance of the sewage disposal system to the new property boundary(s), and the type of septic system. Please be advised that a change in property lines or parcel size may require a change to current sewage disposal methods pursuant to the Plumbing Code.
- f. Names and numbers of all County roads, private roads, and primary or secondary highways
- g. All approaches to the property and balance parcel. Legal access must be provided to each property. Wellsite accesses may not be considered legal accesses.
- h. Approximate location of any waterbodies including lakes, sloughs, creeks, drainage ditches, dugouts, and canals. Contour information (where required) at an interval of 1m is to be superimposed over the tentative plan, and contour data is to be related to a geodetic datum where possible.

4. Copy of Current Certificate of Title(s)

- a. Title(s) search must be current within the last 14 days.
- b. A current copy of the title can be obtained from any license and registrations office or online at <https://alta.registries.gov.ab.ca>. You must have your legal description to order a copy of your title.
- c. If there are any caveats or easements registered on the title pertaining to Beaver County (i.e. deferred reserve caveats or utility easements) please submit copies of these documents along with the application.

5. AER Abandoned Wells Documentation

- a. All new subdivision applications, except for lot line adjustments, must include documentation from the AER (Alberta Energy Regulator) identifying the presence or absence of abandoned wells. Documentation can be obtained from the AER using the online Web Viewer <https://www.aer.ca/data-and-publications/maps-and-mapviewers> and select the "Abandoned Well Map" under Map Viewers. Click on "Area of Interest" on the left hand side, fill in your land location and click "Search". Print a copy of the results and attach to the subdivision application.
- b. If an abandoned gas or oil well is identified on the land that is the subject of a subdivision application, the applicant must include a map that shows the actual well location, as identified in the field, and the setback established by AER in relation to existing or proposed building sites. Contact the Alberta Energy Regulator at 1-855-297-8311 for assistance.

6. Geotechnical Tests

Subdivisions which will have the effect of creating or eventually creating more than two lots that will be serviced by onsite water and/or sewer services should be accompanied by near-surface water table tests, percolation tests for sewage disposal, and potable water supply.

Geotechnical information may also be requested for subdivisions of less than three (3) lots if the Subdivision Authority has reason to believe that the land that is proposed to be subdivided may have significant physical limitations to development, or if the proposed use of the land creates unusual circumstances that require additional consideration.

7. In addition to the above requirements, high density subdivision development will require the following:

a. Conceptual Scheme for Multi-Lot Residential Subdivisions

Any subdivision which would result in four (4) or more lots must first be redistricted to Country Residential. At the time of the redistricting application, a professionally prepared Conceptual Scheme is required, which must include, but is not limited to, the following:

- Proposed subdivision design;
- Professionally prepared bio-physical assessment
- Proposed and adjacent land uses
- Utility servicing
- Traffic impacts
- Identification of abandoned wells (if applicable)
- Development controls (if applicable)

8. Please be advised that:

- a. Reserves may be required for park, school or environmental protection either by way of land dedication, cash in lieu payment, deferred reserve caveat or conservation easement;
- b. Water table and percolation tests may be required to indicate the developable area of the proposed parcel(s);
- c. Pursuant to County policy, road widening, road dedication or new access provision may also be a requirement of subdivision approval; and
- d. A development agreement may be required which would deal with such items as the payment of off-site levies or required site improvements.

9. Additional Information may be required.

FEES ASSOCIATED WITH SUBDIVISION APPLICATION AND APPROVALS

In addition to the information requirements, there will be a number of costs associated with subdividing land. These may include, but are not limited to:

- Initial Subdivision Application fee (\$600 initial application fee, plus \$200 for each new lot)
- Endorsement fee (\$300 per lot, including the remnant)
- Cash-in-lieu of municipal reserve
- Survey, registration, and legal costs
- Road/approach or other upgrading requirements
- Sewer system compliance letter
- Sewer system up-grades (if necessary)

All costs associated with subdivision decisions (application fee, endorsement fee, and any costs required to meet the conditions of subdivision approval) are the responsibility of the applicant/developer.

APPROACH STANDARD (B3)

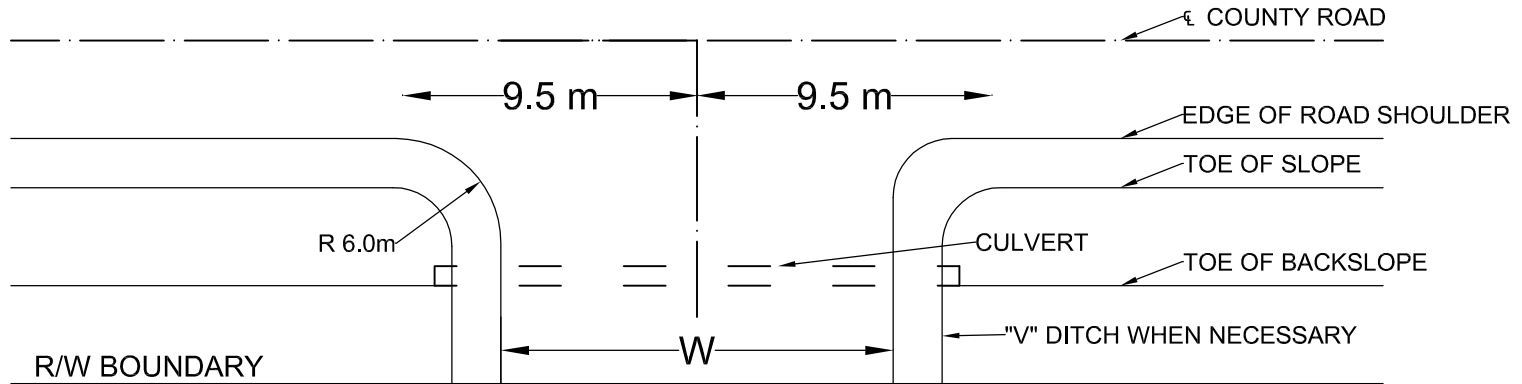

APPROACH PLAN

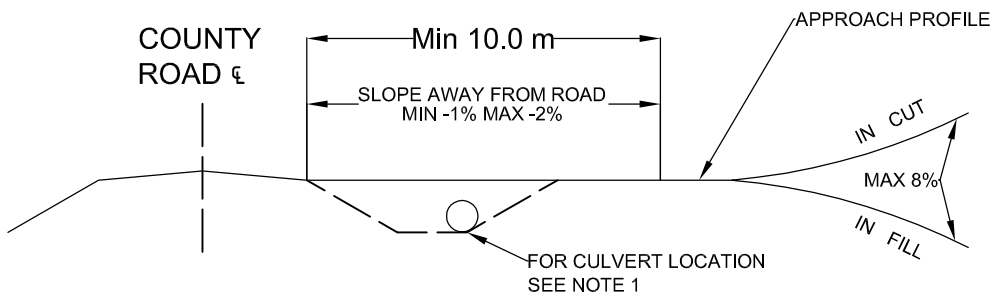

DITCH AND CULVERT LOCATION

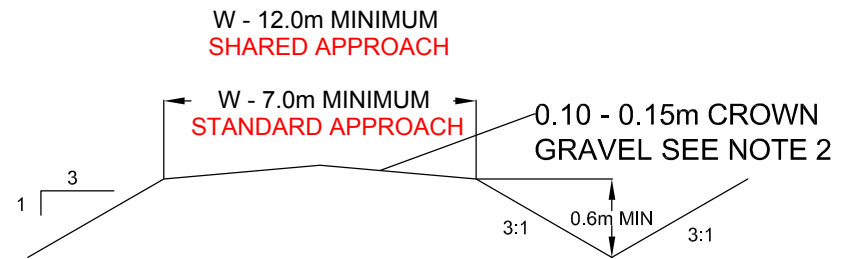

APPROACH CROSS SECTION

NOTES

- 1) When culverts are required for approaches, they must be corrugated steel pipe and be a minimum of 300mm diameter, no smaller than the direct upstream culvert
 - a) Length will vary with depth of fill
 - b) Culvert to be placed at toe of backslope
- 2) A minimum of 8 m³ of maximum 50mm crushed gravel is to be applied to the approach
- 3) All dimensions shown are in meters
- 4) Minimum approach length is from road shoulder to right of way boundary

ROAD STANDARD (B1)

Right Of Way Requirements

Right of way 20 meters with backsloping
Easement for construction

Cross-section Elements

Finished Road Top 7 meters
Grade slope- 1 meter vertical @ 3:1
Ditch- Flat bottom @ 3.0 meter width
Backsloping- Minimum 3:1

Geometric Requirements

Maximum gradient- 6%
Minimum Crest Vertical Curvature- K45
Minimum Sag Vertical Curvature- K 30
Minimum Horizontal Curvature- 300 meter radius
Maximum Super Elevation- 6%

Structural Requirements

Surface Aggregate- Designation 4 Class 20 material, 275 tonnes per km
Grade- 0.90m minimum non- organic material with 0.20 meters of clay cap (if possible)
Compaction- Upper 0.30m- 100% of Standard Proctor Density
Below 0.30m- 95% Standard Proctor Density
Moisture Content- Optimum Moisture Content

